

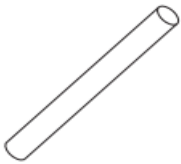





Article number 1001713/1001714

# ASSEMBLY INSTRUCTIONS

Please read the instructions carefully for correct and safe assembly.



<b>Ax1</b> 	<b>Bx1</b> 	<b>Cx1</b> 	<b>Dx1</b> 
<b>Ex2</b>  10MM	<b>Fx1</b>  10x20x1.5	<b>Gx1</b>  17MM	

# ASSEMBLY INSTRUCTIONS

Please read the instructions carefully for correct and safe assembly.

**1**

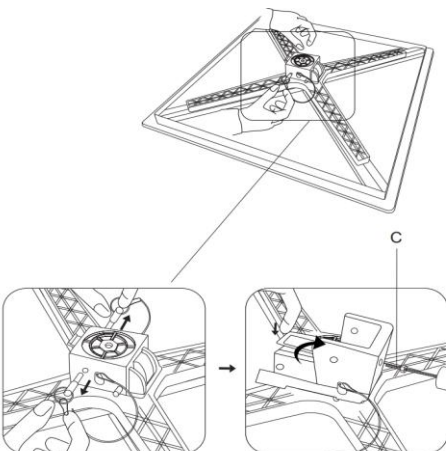

Step 1: Pull out the folding and fixing locks on both sides

Step 2: Press the pressure plate and open the folding board

**2**

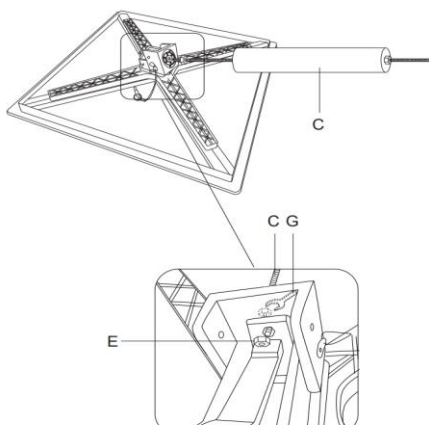

Step 3: Fix Nut E on screw C, pls note don't let C be higher than E, they should remian level with each other. Then use G to tighten nut E

**3**

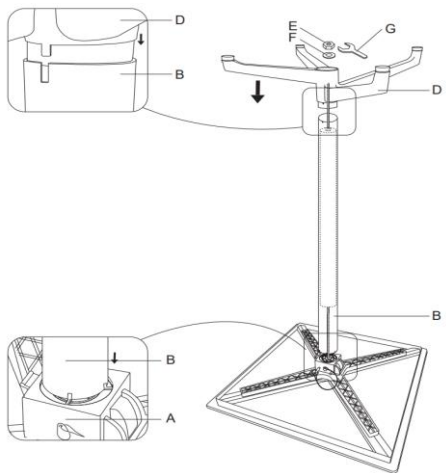



Diagram 3 shows the assembly of the top board. It includes a detailed view of the board's locking mechanism with labels A, B, and D. The main diagram shows the board being lowered onto the central column (B) and secured with a nut (G) and a screw (F). The base of the stand is also labeled B.

**4**



No need to fully insert the lock