

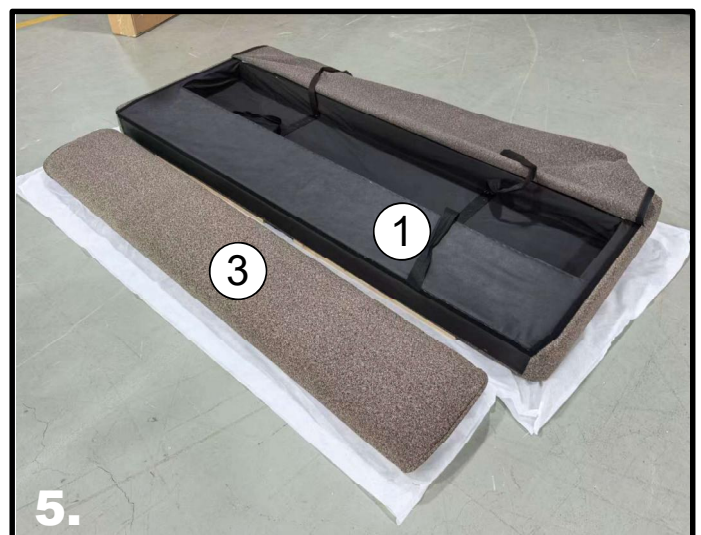

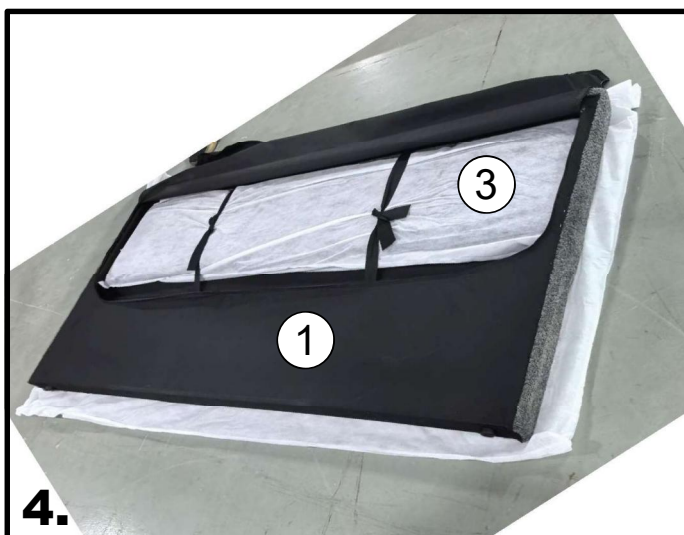

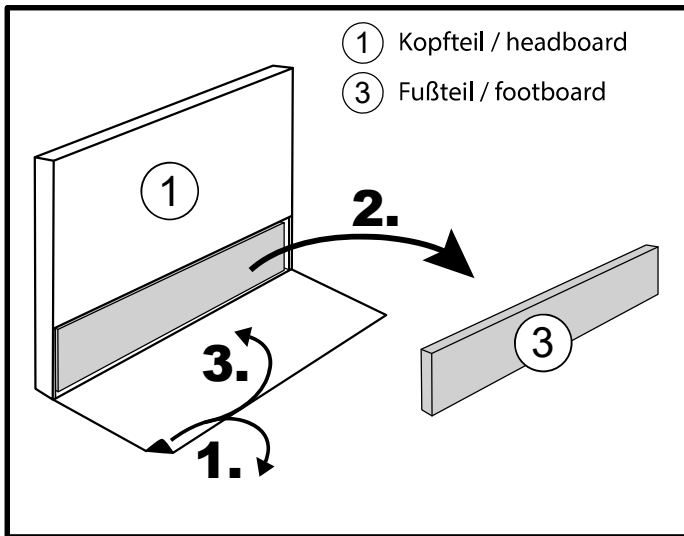





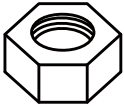
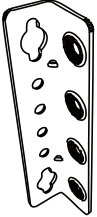

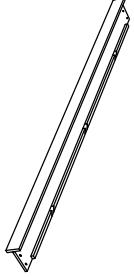
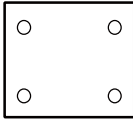
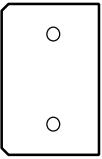
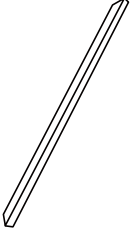

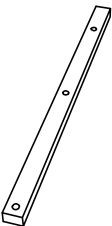

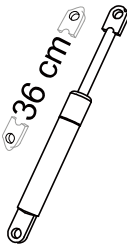
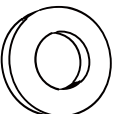
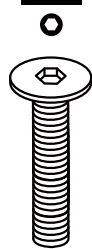
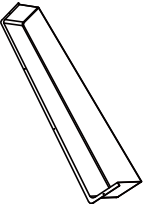

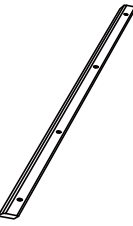
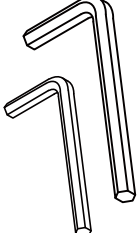
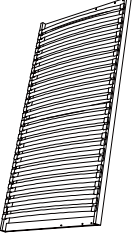
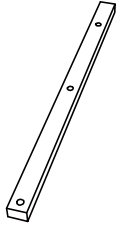

## Fußteil im Kopfteil Footboard inside of the headboard

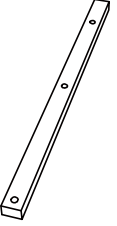
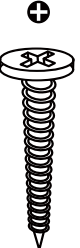

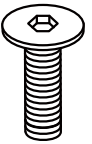
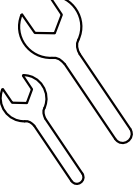
Meise Möbel GmbH & KG Klosterbauerschafter Straße 27 D-32278 Kirchlengern		<b>ALVA</b> by meise (JF7986) Bettkasten / storage						160 cm 180 cm 200 cm
A-108	B-108	C-108	D-108	E-108	F-108	G-108	H-108	I-108
4	4	6	28	4	1	2	4	6
								
H 180	M8	-	M6*30	M6*20	2010*152*70	160/180/200: 790/890/990* 850*5	160/180/200: 790/890/990* 575*5	160/180/200: 790/890/990*50*12
J-108	K-108	LL/LR-108	M-108	N-108	O-108	P-108	Q-108	R-108
16	2	2 / 2	4	-	4	14	4	16
				-				
Set	560*30*30	-	350 N	-	M8*25	M8*60	730*95*60	4*20
S-108	T-108	UL/UR-108	V-108	W-108	X-108	Y-108	Z-108	AC-108
2	1 / 1	1 / 1	2	8	8	4	2	6
								
1580*36*36	4 / 5	160/180/200: 79/89/99*195cm	560*30*10	M6*19	M6	-	160/180/200: 590/690/790* 22*22	4*40
AD-108	AG-108							
22	1 / 1							
								
M8*40	10 / 13							
								
Werk 108 / 16.12.2025		1 / 5						

**1**

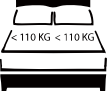
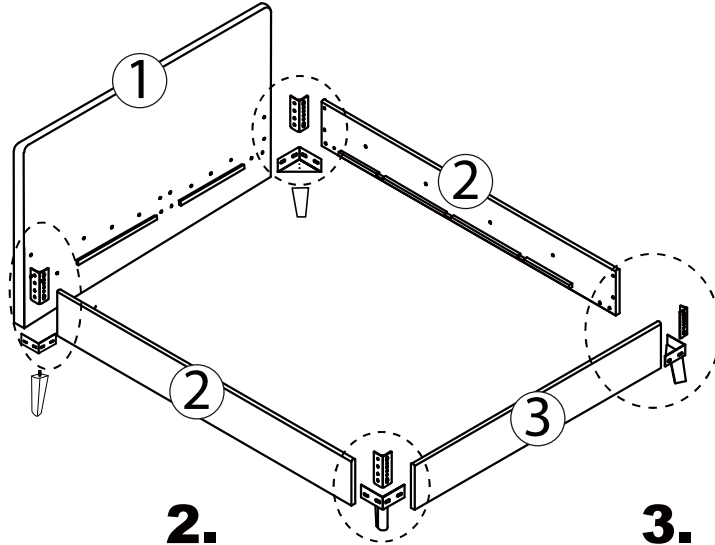

**1.**

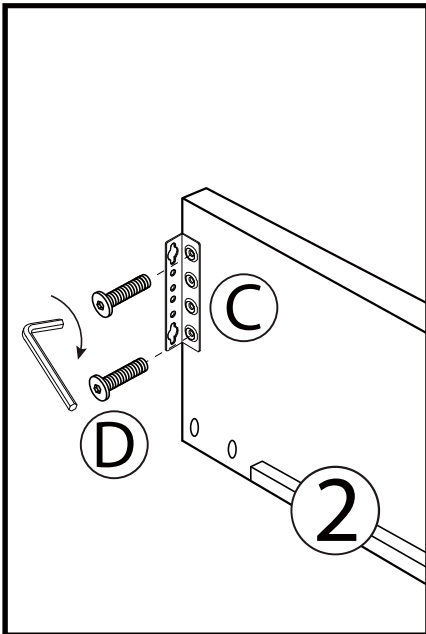

**2.**

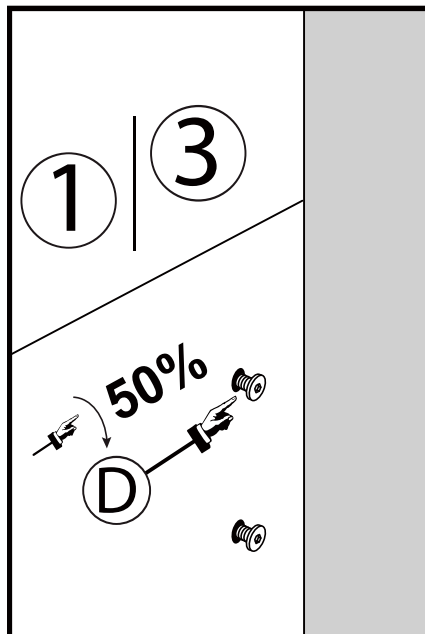

**3.**

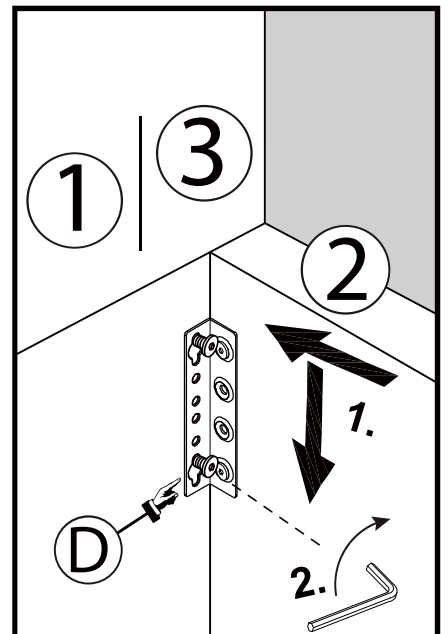

**4.**

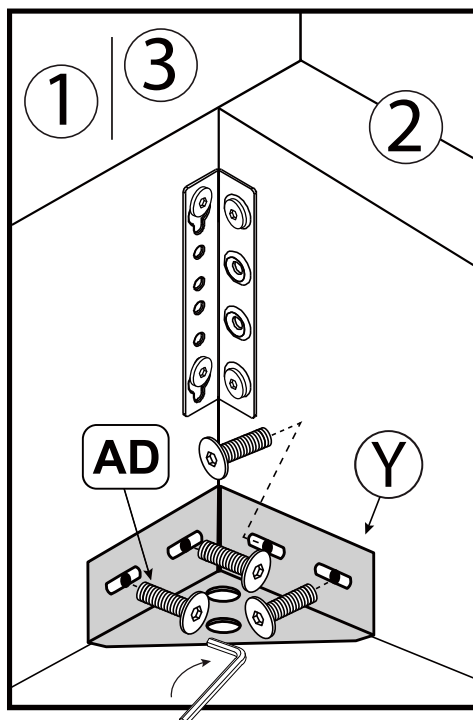

**5. !**

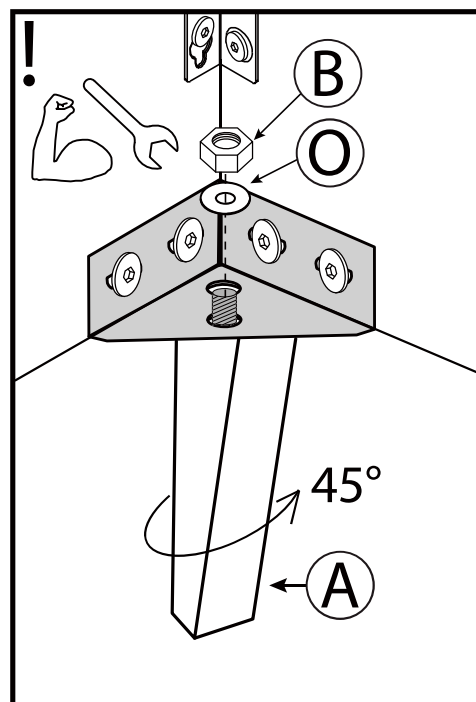

2

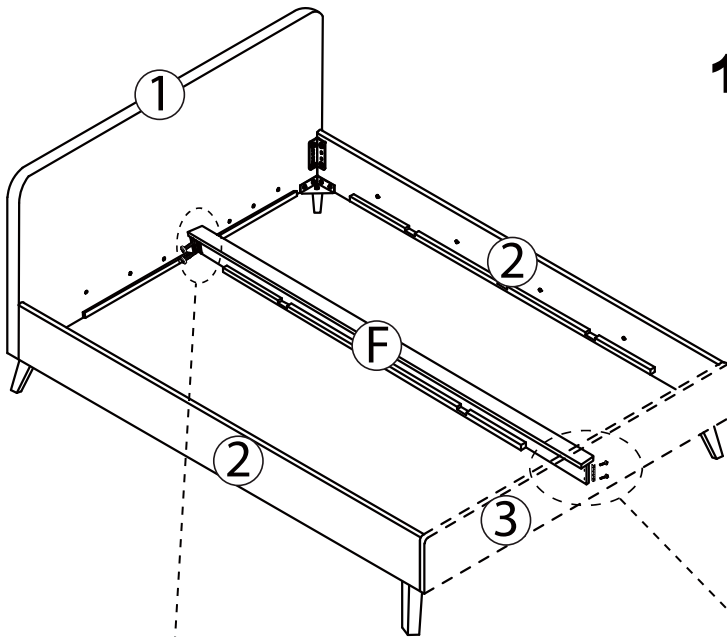

1.

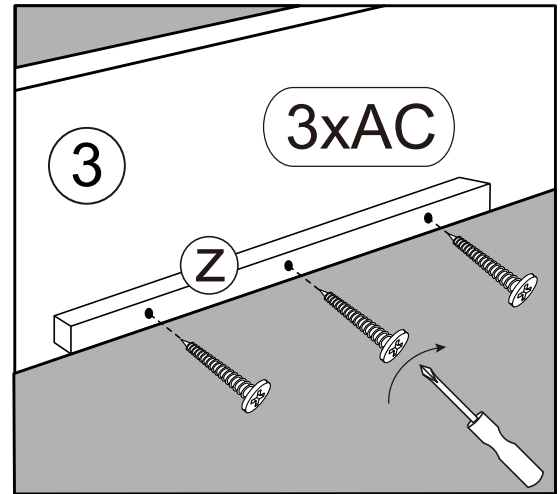

2.

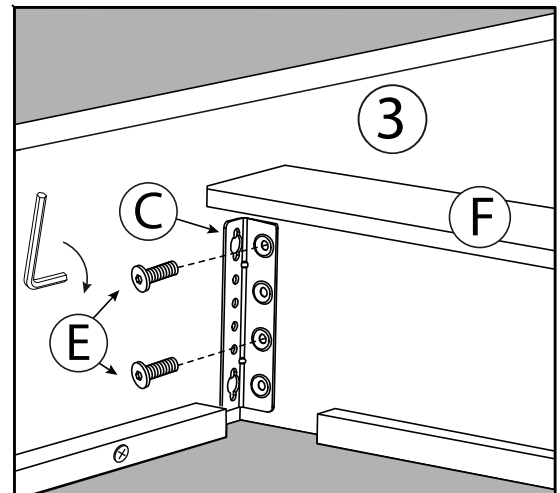
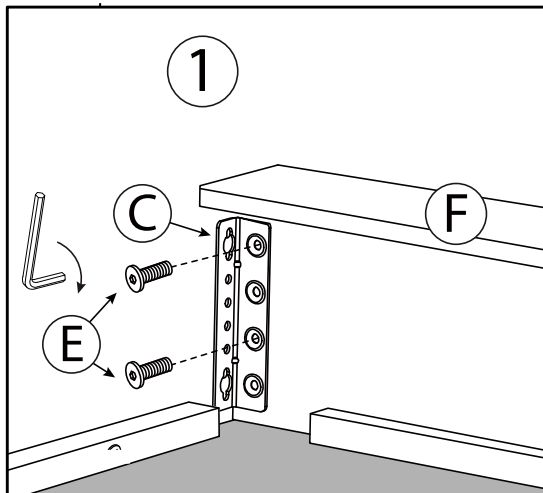

3.

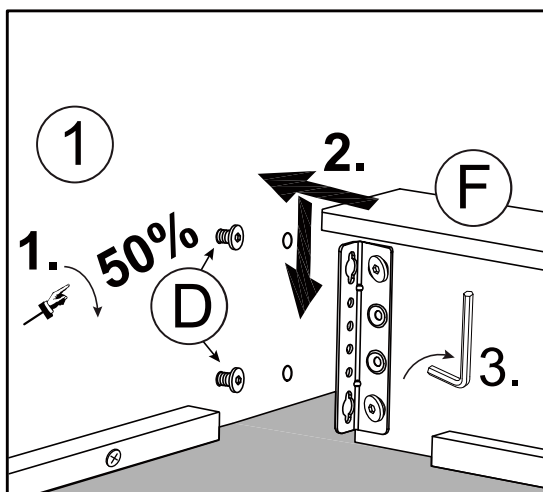

4.

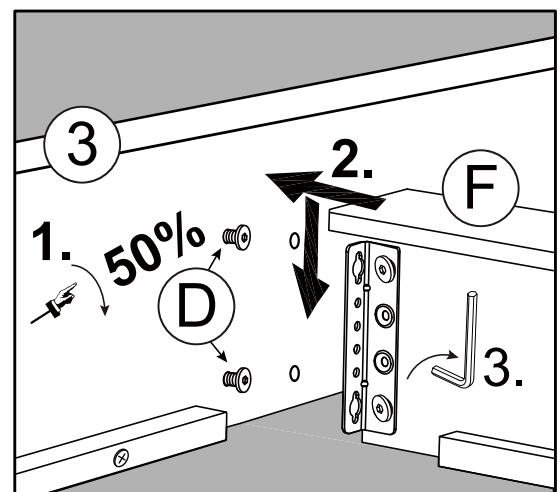

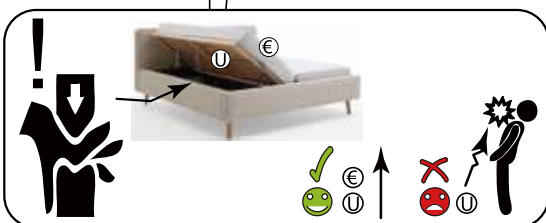
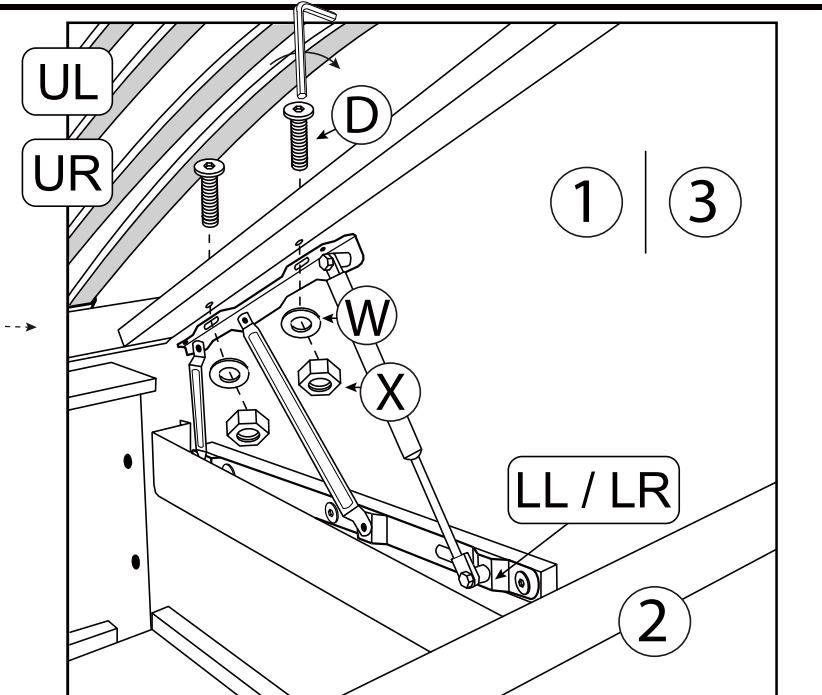
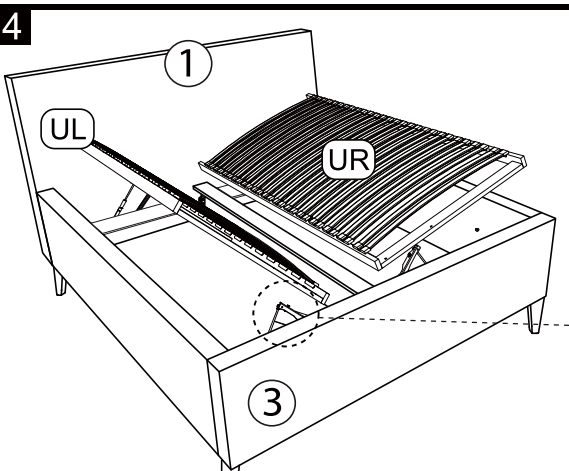
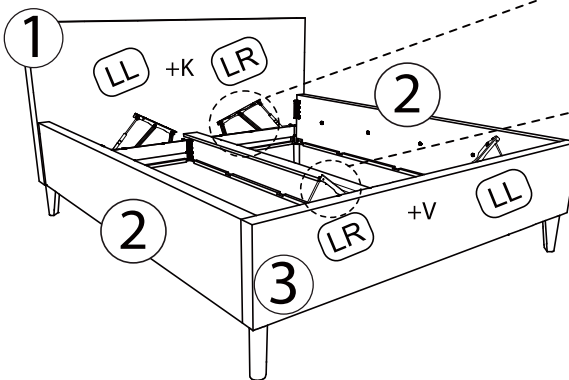
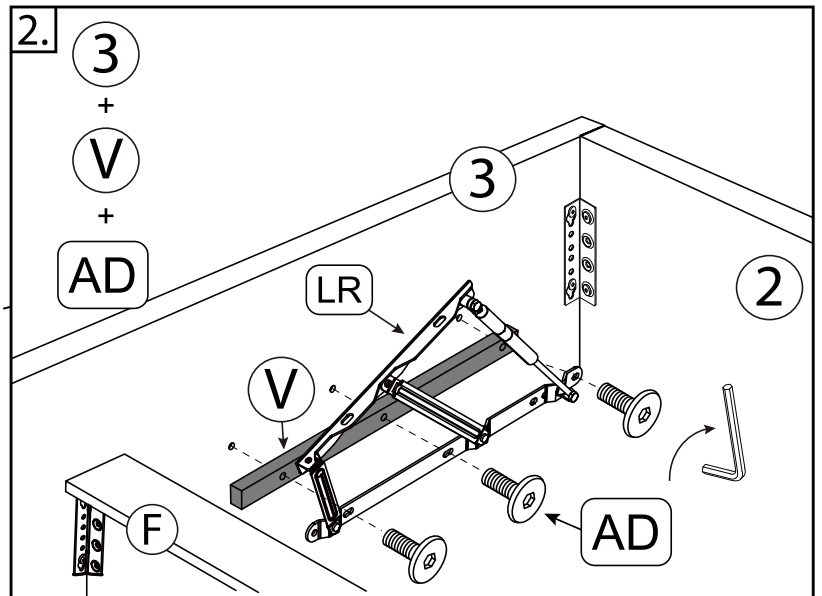
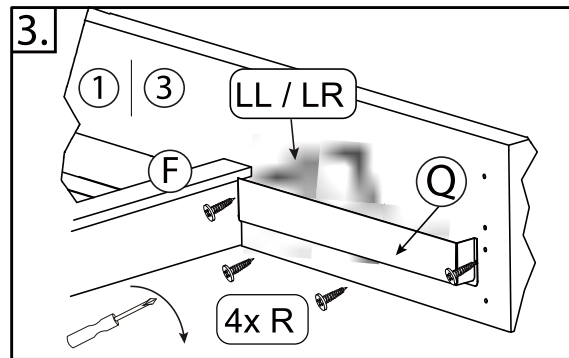
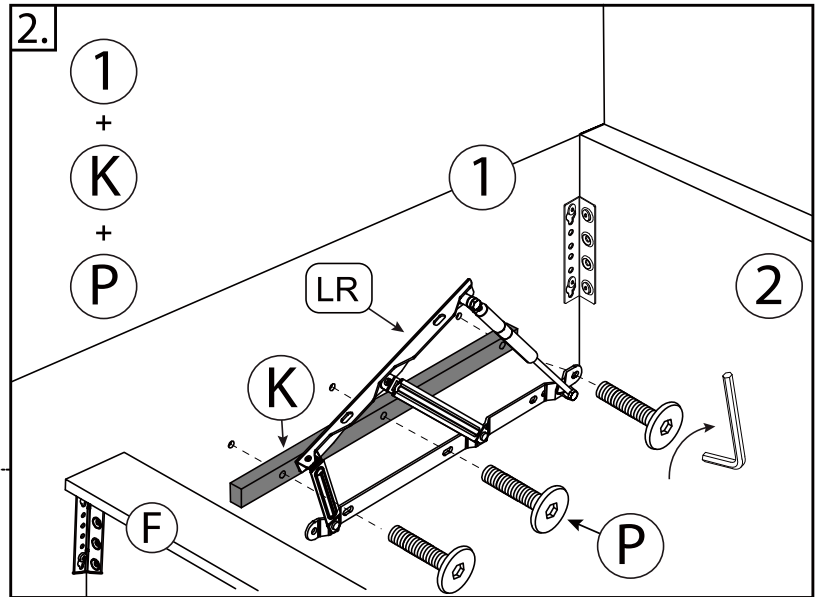
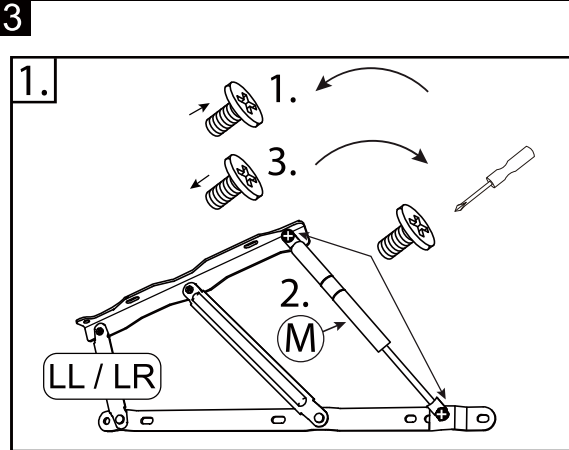





„Wichtig: Gebrauchs- und Montageanleitung für spätere Bezugnahme aufbewahren, sorgfältig lesen“

"Important: for future reference please keep the assembly instruction, read it carefully"

„Important : Notice d'utilisation et de montage pour toute référence ultérieure, à conserver et à lire attentivement.“

**Modelle** mit Lichtquellen: Die Lichtquellen und die separaten Steuerungselemente können zur Überprüfung durch die Marktüberwachungsbehörde / als Austauschteil aus dem umgebenden Produkt entnommen werden, ohne sie dauerhaft zu zerstören.

**Models** incl. LED Light: The light sources and the separate control elements can be removed from the surrounded product for inspection by the market surveillance authority / as replacement part without permanently destroying them. Instructions for this can be found in the technical documentation of the product.

**Modèles** avec sources lumineuses : Les sources lumineuses et les éléments de commande séparés peuvent être retirés du produit environnant pour être contrôlés par l'autorité de surveillance du marché / en tant que pièce de rechange sans être détruits de manière permanente. Vous trouverez des instructions à ce sujet dans la documentation technique du produit.

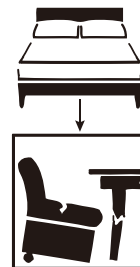
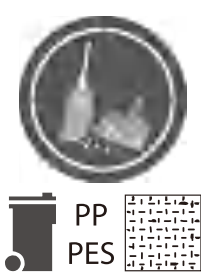
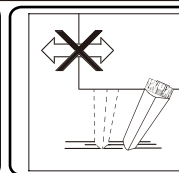
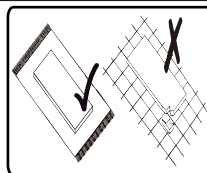
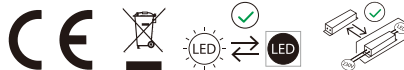

Sperrmüll / bulky waste / Déchets encombrants

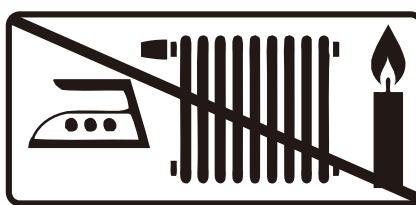
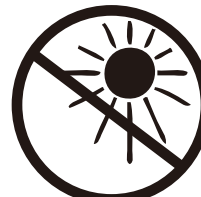
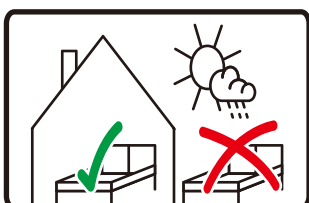
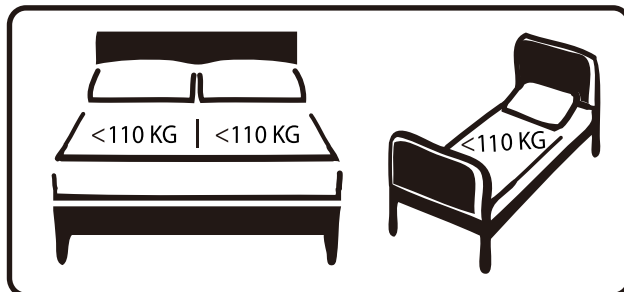
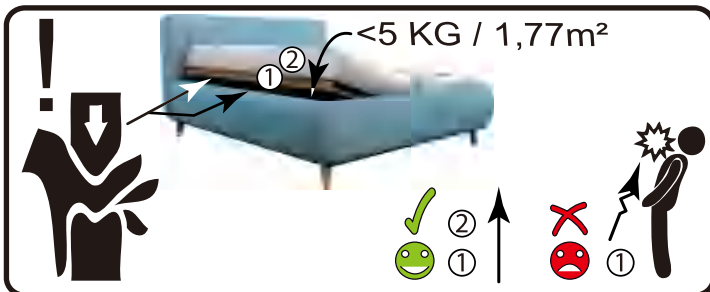

инструкции за монтаж / návod k montáži / monteringsvejledning / instrucciones de montaje / monteerimisjuhendid / instructions de montage / asennusohjeet / οδηγίες συναρμολόγησης / szerelési útmutató / upute za montažu / istruzioni di montaggio / montāžas instrukcijas / surinkimo instrukcijos / montage-instructies / instruções de montagem / instrukcja montażu / instrucțiunile de asamblare / инструкции по сборке / monteringsanvisningar / návod na montáž / navodila za montažo / montaj talimatları



„Wichtig: Gebrauchs- und Montageanleitung für spätere Bezugnahme aufbewahren, sorgfältig lesen“

"Important: for future reference please keep the assembly instruction, read it carefully"

„Important : Notice d'utilisation et de montage pour toute référence ultérieure, à conserver et à lire attentivement.“

**Modelle** mit Lichtquellen: Die Lichtquellen und die separaten Steuerungselemente können zur Überprüfung durch die Marktüberwachungsbehörde / als Austauschteil aus dem umgebenden Produkt entnommen werden, ohne sie dauerhaft zu zerstören.

**Models** incl. LED Light: The light sources and the separate control elements can be removed from the surrounded product for inspection by the market surveillance authority / as replacement part without permanently destroying them. Instructions for this can be found in the technical documentation of the product.

**Modèles** avec sources lumineuses : Les sources lumineuses et les éléments de commande séparés peuvent être retirés du produit environnant pour être contrôlés par l'autorité de surveillance du marché / en tant que pièce de rechange sans être détruits de manière permanente. Vous trouverez des instructions à ce sujet dans la documentation technique du produit.

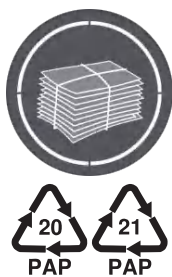
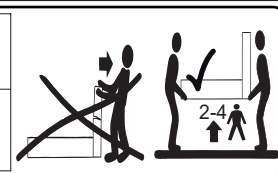
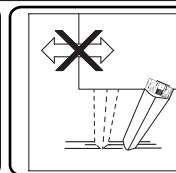
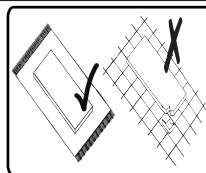
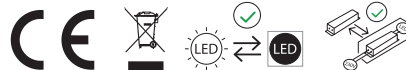

Sperrmüll / bulky waste / Déchets encombrants

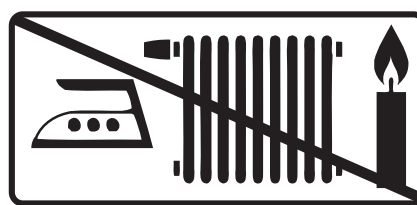
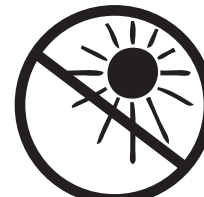
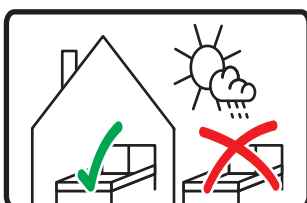
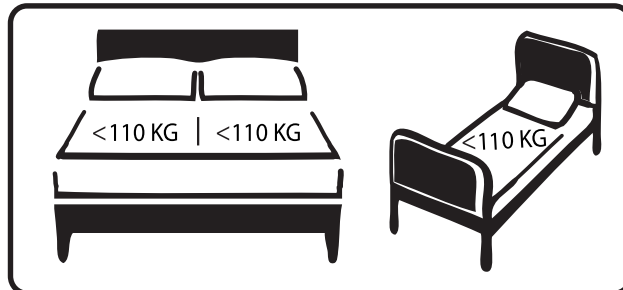
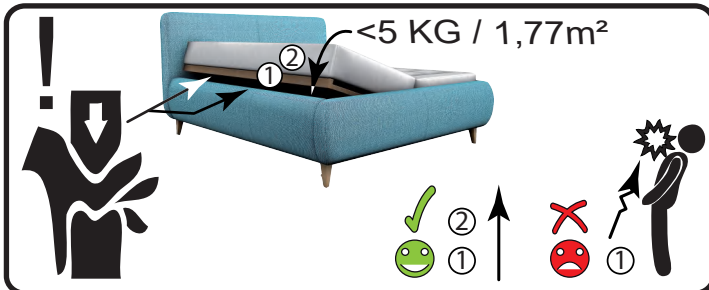

инструкции за монтаж / návod k montáži / monteringsvejledning / instrucciones de montaje / monteerimisjuhendid / instructions de montage / asennusohjeet / οδηγίες συναρμολόγησης / szerelési útmutató / upute za montažu / istruzioni di montaggio / montāžas instrukcijas / surinkimo instrukcijos / montage-instructies / instruções de montagem / instrukcja montażu / instrucțiunile de asamblare / инструкции по сборке / monteringsanvisningar / návod na montáž / navodila za montažo / montaj talimatları